

HFT2-300

HOT FOOD TABLE

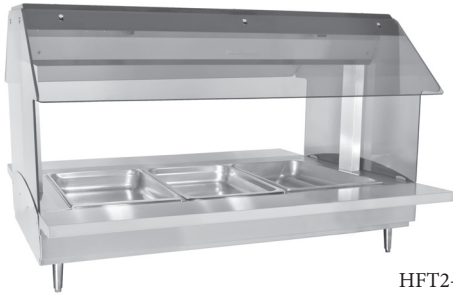

HFT2-300



HFT2SYS-300 (Standard)



- HALO HEAT ... a controlled, uniform heat source that gently holds and surrounds food for better appearance, taste, and longer holding life.
- Freestanding, self-service merchandiser designed to hold and display hot food fresh and moist for hours — without adding water.
- Lighted display maximizes visual merchandising — promotes impulse sales.
- Heat source radiates from the base and the upper canopy with adjustable temperature settings.
- Concealed power and temperature switches are easily accessible to the operator.
- Maintenance savings with the elimination of lime and scale buildup associated with steam table holding.
- Angled canopy on two sides adds to the clean streamlined look.
- Tray slides on each side add customer self-service convenience and safety.
- Full Lexan side panels provide protective enclosure.

20 gauge stainless steel hot food table features an 18 gauge stainless steel hot well, and two (2) full length stainless steel tray slides. The 4-3/8" (111mm) deep hot well accepts three (3) full-size (gastronorm) pans and is controlled by an adjustable thermostat with a range of 1 through 10. Two (2) full-size pan divider bars and six (6) half/third-size pan divider bars are included. The overhead canopy is supported by two (2) side supports, enclosing six (6) flood lamps and is surrounded by four (4) removable tempered glass heat guards. A toggle switch located beneath the canopy controls the power (ON/OFF). Counter-top model includes a set of four (4) adjustable 4" (102mm) legs.

System base comes standard with two (2) side panels, two (2) adjustable shelves, and is furnished with four (4) 5" (127mm) casters, 2 rigid, and 2 swivel with brake.

- MODEL HFT2-300: Counter-top Hot Food Table, 48" (1220mm) wide
- MODEL HFT2SYS-300: Hot Food Table with System Base, 48" (1220mm) wide



ANSI/NSF 4



FACTORY INSTALLED OPTIONS

- Electrical Choices
 - Specify Voltage:
 - 208-240
 - 230
- System Decorator Base (floor standing)
 - Specify option:
 - Standard - includes stainless steel base, choice of side panels, and two (2) adjustable stainless steel shelves.
 - Deluxe - features formica end panels and canopy, four (4) wooden adjustable shelves and two (2) removable wooden side baskets.
- Panel Color Choices
 - Specify color:
 - Black
 - Stainless Steel
 - Custom Color

Архангельск (8182)63-90-72
 Астана (7172)727-132
 Астрахань (8512)99-46-04
 Барнаул (3852)73-04-60
 Белгород (4722)40-23-64
 Брянск (4832)59-03-52
 Владивосток (423)249-28-31
 Волгоград (844)278-03-48
 Вологда (8172)26-41-59
 Воронеж (473)204-51-73
 Екатеринбург (343)384-55-89
 Иваново (4932)77-34-06

Ижевск (3412)26-03-58
 Иркутск (395)279-98-46
 Казань (843)206-01-48
 Калининград (4012)72-03-81
 Калуга (4842)92-23-67
 Кемерово (3842)65-04-62
 Киров (8332)68-02-04
 Краснодар (861)203-40-90
 Красноярск (391)204-63-61
 Курск (4712)77-13-04
 Липецк (4742)52-20-81
 Киргизия (996)312-96-247

Магнитогорск (3519)55-03-13
 Москва (495)268-04-70
 Мурманск (8152)59-64-93
 Набережные Челны (8552)20-53-41
 Нижний Новгород (831)429-08-12
 Новокузнецк (3843)20-46-81
 Новосибирск (383)227-86-73
 Омск (3812)21-46-40
 Орел (4862)44-53-42
 Оренбург (3532)37-68-04
 Пенза (8412)22-31-16
 Казахстан (772)734-952-31

Пермь (342)205-81-47
 Ростов-на-Дону (863)308-18-15
 Рязань (4912)46-61-64
 Самара (846)206-03-16
 Санкт-Петербург (812)309-46-40
 Саратов (845)249-38-78
 Севастополь (8692)22-31-93
 Симферополь (3652)67-13-56
 Смоленск (4812)29-41-54
 Сочи (862)225-72-31
 Ставрополь (8652)20-65-13
 Таджикистан (992)427-82-92-69

Сургут (3462)77-98-35
 Тверь (4822)63-31-35
 Томск (3822)98-41-53
 Тула (4872)74-02-29
 Тюмень (3452)66-21-18
 Ульяновск (8422)24-23-59
 Уфа (347)229-48-12
 Хабаровск (4212)92-98-04
 Челябинск (351)202-03-61
 Череповец (8202)49-02-64
 Ярославль (4852)69-52-93

<https://altoshaam.nt-rt.ru/> || ama@nt-rt.ru



HFT2-300

HOT FOOD TABLE

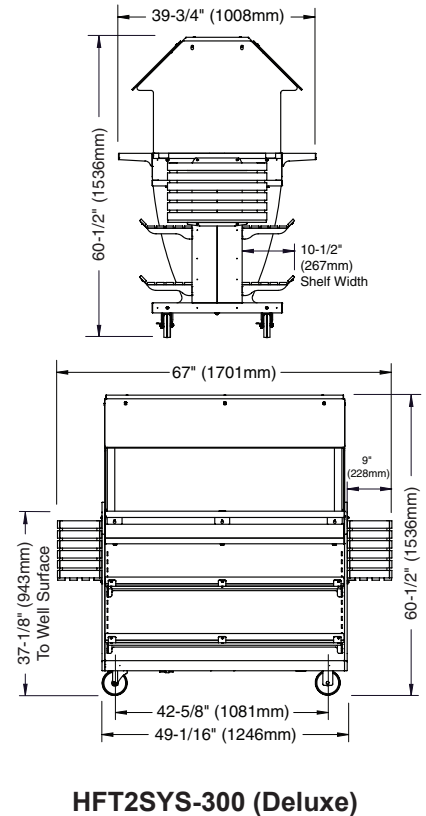
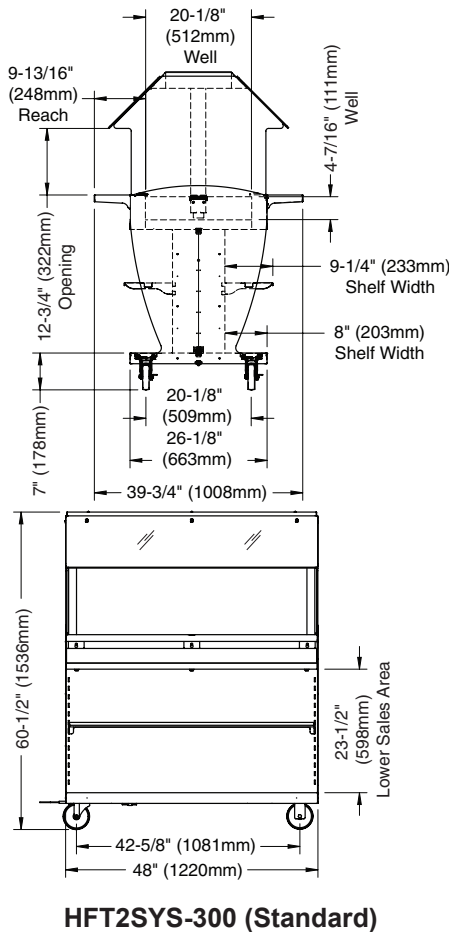
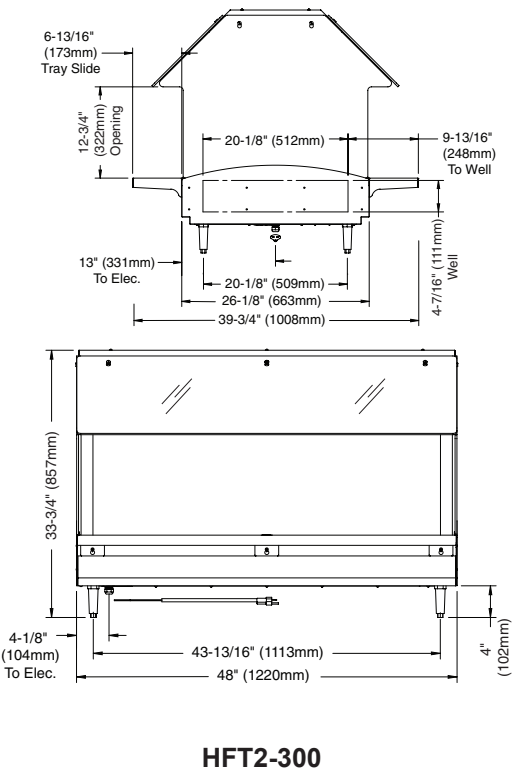

HFT2-300 ELECTRICAL					
VOLTAGE	PHASE	CYCLE/HZ	AMPS	kw	PLUG CONFIGURATION
208 - 240	1	60	13.0 - 15.0	2.7 - 3.6	NEMA 6-20P 20A - 250V PLUG
230	1	50	14.7	3.4	CEE 7/7, 220-230V PLUG

WEIGHT			
	HFT2-300	HFT2SYS-300 (Std.)	HFT2SYS-300 (Dlx.)
NET:	160 lbs (73 kg)	286 lbs (130 kg)	430 lbs (195 kg)
SHIP:	280 lbs (127 kg)	365 lbs (166 kg)	509 lbs (231 kg)

CRATE DIMENSIONS: (L X W X H)
 HFT2-300 - CONTACT FACTORY
 HFT2SYS-300 - 60" x 38" x 68" (1524mm x 965mm x 1727mm)

INSTALLATION REQUIREMENTS

Hot food table must be installed level. The table must not be installed in any area where it may be affected by steam, grease, dripping water, high temperatures, or any other severely adverse conditions.

Do not install a hot food table near a cold air source such as a freezer, air conditioning vents, or in any area where outside air fluctuation can affect performance.

DIMENSIONS (H X W X D)	
HFT2-300 EXTERIOR:	33-3/4" x 48" x 39-3/4" (857mm x 1220mm x 1008mm)
HFT2SYS-300 (STANDARD) EXTERIOR:	60-1/2" x 48" x 39-3/4" (1536mm x 1220mm x 1008mm)
HFT2SYS-300 (DELUXE) EXTERIOR:	60-1/2" x 67" x 39-3/4" (1536mm x 1701mm x 1008mm)
HOT WELL DIMENSIONS (H X W X D):	4-7/16" x 38" x 20-1/8" (111mm x 964mm x 512mm)

PRODUCT PAN CAPACITY	
62 lb (30 kg) MAXIMUM (BASED ON 4" (100mm) DEEP PANS) MAX. VOLUME: 45 qt (57 L)	
FULL-SIZE PANS*:	Three (3) 12" x 20" x 4" GN 1/1 (325mm x 530mm x 102mm)
HALF-SIZE PANS*:	Six (6) 12" x 10" x 4" GN 1/2 (325mm x 265mm x 102mm)
THIRD-SIZE PANS*:	Nine (9) 12" x 6" x 4" GN 1/3 (325mm x 176mm x 102mm)
*WILL ALSO ACCEPT 2-1/2" (65mm) DEEP PANS. PANS NOT INCLUDED.	

Архангельск (8182)63-90-72
 Астана (7172)727-132
 Астрахань (8512)99-46-04
 Барнаул (3852)73-04-60
 Белгород (4722)40-23-64
 Брянск (4832)59-03-52
 Владивосток (423)249-28-31
 Волгоград (844)278-03-48
 Вологда (8172)26-41-59
 Воронеж (473)204-51-73
 Екатеринбург (343)384-55-89
 Иваново (4932)77-34-06

Ижевск (3412)26-03-58
 Иркутск (395)279-98-46
 Казань (843)206-01-48
 Калининград (4012)72-03-81
 Калуга (4842)92-23-67
 Кемерово (3842)65-04-62
 Киров (8332)68-02-04
 Краснодар (861)203-40-90
 Красноярск (391)204-63-61
 Курск (4712)77-13-04
 Липецк (4742)52-20-81
 Киргизия (996)312-96-26-47

Магнитогорск (3519)55-03-13
 Москва (495)268-04-70
 Мурманск (8152)59-64-93
 Набережные Челны (8552)20-53-41
 Нижний Новгород (831)429-08-12
 Новокузнецк (3843)20-46-81
 Новосибирск (383)227-86-73
 Омск (3812)21-46-40
 Орел (4862)44-53-42
 Оренбург (3532)37-68-04
 Пенза (8412)22-31-16
 Казахстан (772)734-952-31

Пермь (342)205-81-47
 Ростов-на-Дону (863)308-18-15
 Рязань (4912)46-61-64
 Самара (846)206-03-16
 Санкт-Петербург (812)309-46-40
 Саратов (845)249-38-78
 Севастополь (8692)22-31-93
 Симферополь (3652)67-13-56
 Смоленск (4812)29-41-54
 Сочи (862)225-72-31
 Ставрополь (8652)20-65-13
 Таджикистан (992)427-82-92-69

Сургут (3462)77-98-35
 Тверь (4822)63-31-35
 Томск (3822)98-41-53
 Тула (4872)74-02-29
 Тюмень (3452)66-21-18
 Ульяновск (8422)24-23-59
 Уфа (347)229-48-12
 Хабаровск (4212)92-98-04
 Челябинск (351)202-03-61
 Череповец (8202)49-02-64
 Ярославль (4852)69-52-93