

# Combitherm® CTC20-20E

## Electric Boiler-free

Combining multiple cooking functions into a single appliance, Combitherm® ovens provide endless versatility, reliability and unmatched performance. An all-in-one solution for efficient and consistent food production. Combitherm ovens do the work of a convection oven, kettle, steamer, fryer, smoker and more. Execute every dish, no matter how simple or complex, faster than ever with flawless precision and consistency.

### Standard features

- Simple and intuitive push button control that commands all oven functions with easily identifiable icons
- LED display indicating cooking mode, temperature settings, time remaining, and various instructions
- LED illuminated door handle designed for the needs of the busy kitchen, and provides visual notification of the oven status
- CoolTouch3™ triple panel glass door keeps the heat inside, while keeping the glass cool to the touch and providing 15% greater thermal retention to improve performance and efficiency
- Three cooking modes—steam, convection, and combination
- Front-accessible and retractable rinse hose
- Two different fan speeds
- One fully automated cleaning cycle



**20** Twenty full-size sheet pans, twenty GN 2/1 pans; forty full-size hotel or GN 1/1 pans; two rows deep

Roll-in pan cart with twenty non-tilt support rails; 20" [508mm] horizontal width between rails, 2-9/16" [65mm] vertical spacing between rails

480 lb [218 kg] product maximum

300 quarts [380 liters] volume maximum

Ten [10] wire shelves included. Additional wire shelves required for maximum capacity.

Condensable Particulate Matter [CPM] emissions produced through the most aggressive testing methods available were measured at 0.77 mg/m<sup>3</sup> for 11,660 beef patties which is below the maximum allowable level of 5.0 mg/m<sup>3</sup> established by EPA test method 202. This product is UL listed under KNLZ in the U.S. and Canada.

Cooking appliance with integral systems for limiting the emission of grease laden air IP35.



CTC20-20E

### Configurations (select one)

#### Door swing

- Right hinged
- Recessed door, optional (not available on ventless hood)

#### Electrical

- 208-240V 3ph
- 440-480V 3ph
- 380-415V 3ph

### Accessories (select all that apply)

- CombiLatch™
- Extended one-year warranty

### Probe choices

- Removable, single-point, quick-connect core temperature probe, optional
- Removable, single-point, quick-connect sous vide temperature probe, optional

### Security devices for correctional facility use

- Optional base package (not available with recessed door): includes tamper-proof screw package, excludes temperature probe
- Anti-entrapment device, optional
- Control panel security cover, optional
- Hasp door lock (padlock not included), optional
- Removable, single-point, quick-connect core temperature probe, optional

### Installation options (select one)

- Alto-Shaam Combination Factory Authorized Installation Program - available in the U.S. and Canada only
- Installation Start-Up Check - available through an Alto-Shaam authorized service agency

Архангельск (8182)63-90-72  
Астана (7172)727-132  
Астрахань (8512)99-46-04  
Барнаул (3852)73-04-60  
Белгород (4722)40-23-64  
Брянск (4832)59-03-52  
Владивосток (423)249-28-31  
Волгоград (844)278-03-48  
Вологда (8172)26-41-59  
Воронеж (473)204-51-73  
Екатеринбург (343)384-55-89  
Иваново (4932)77-34-06

Ижевск (3412)26-03-58  
Иркутск (395)279-98-46  
Казань (843)206-01-48  
Калининград (4012)72-03-81  
Калуга (4842)92-23-67  
Кемерово (3842)65-04-62  
Киров (8332)68-02-04  
Краснодар (861)203-40-90  
Красноярск (391)204-63-61  
Курск (4712)77-13-04  
Липецк (4742)52-20-81  
Киргизия (996)312-96-26-47

Магнитогорск (3519)55-03-13  
Москва (495)268-04-70  
Мурманск (8152)59-64-93  
Набережные Челны (8552)20-53-41  
Нижний Новгород (831)429-08-12  
Новокузнецк (3843)20-46-81  
Новосибирск (383)227-86-73  
Омск (3812)21-46-40  
Орел (4862)44-53-42  
Орэнбург (3532)37-68-04  
Пенза (8412)22-31-16  
Казахстан (772)734-952-31

Пермь (342)205-81-47  
Ростов-на-Дону (863)308-18-15  
Рязань (4912)46-61-64  
Самара (846)206-03-16  
Санкт-Петербург (812)309-46-40  
Саратов (845)249-38-78  
Севастополь (8692)22-31-93  
Симферополь (3652)67-13-56  
Смоленск (4812)29-41-54  
Сочи (862)225-72-31  
Ставрополь (8652)20-65-13  
Таджикистан (992)427-82-92-69

Сургут (3462)77-98-35  
Тверь (4822)63-31-35  
Томск (3822)98-41-53  
Тула (4872)74-02-29  
Тюмень (3452)66-21-18  
Ульяновск (8422)24-23-59  
Уфа (347)229-48-12  
Хабаровск (4212)92-98-04  
Челябинск (351)202-03-61  
Череповец (8202)49-02-64  
Ярославль (4852)69-52-93

# Combitherm® CTC20-20E

## Specification

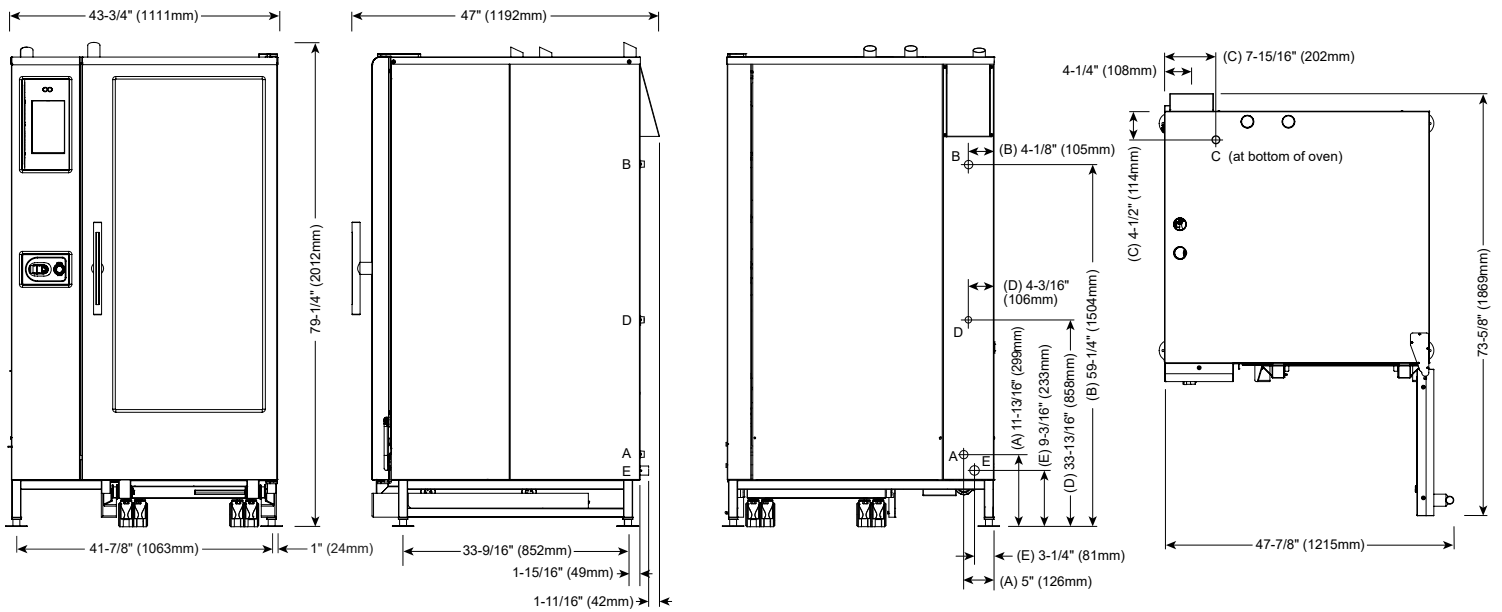

A = Untreated water    B = Treated water    C = Electrical (Bottom)  
 D = Gas (unused)    E = Water drain



### DIMENSIONS

**Model**  
 CTC20-20E

**Exterior (H x W x D)**  
 79-1/4" x 43-3/4" x 47" [2012mm x 1111mm x 1192mm]  
**Exterior with recessed door (H x W x D)**  
 79-1/4" x 48-3/4" x 47" [2012mm x 1238mm x 1192mm]

**Interior (H x W x D)**  
 60-7/16" x 24-1/4" x 32-3/4" [1535mm x 616mm x 832mm]  
**Net Weight**  
 1100 lb [499 kg]

CTC20-20E

**Ship Dimensions (L x W x H)\***  
 53" x 53" x 87" [1346mm x 1346mm x 2210mm]

**Ship Weight\***  
 1157 lb [525 kg]



### CLEARANCE

Top: 20" [508mm]  
 Left: 0" [0mm]  
 18" [457mm] recommended service access  
 Right: 0" [0mm] Non-combustible surfaces  
 2" [51mm] combustible surfaces  
 Bottom: 5-1/8" [130mm]  
 Back: 4" [102mm]  
 4-5/16" [109mm] optional plumbing kit



### CHECK FIRST

- Oven must be installed level.
- Water supply shut-off valve and back-flow preventer when required by local code.
- Hood installation is required.
- Drain must not be located directly underneath the appliance.

# Combitherm® CTC20-20E



## Heat of rejection

CTC20-20E	Heat Gain qs, BTU/hr	Heat Gain qs, kW
	3,942	1.15



## Noise emissions

Without hood system, a maximum 67 dBA was measured at 3.3 ft [1 m] from unit.

With hood system, a maximum 81 dBA was measured at 3.3 ft [1 m] from unit.



CTC20-20E	V	Ph	Hz	Awg	A	Breaker	kW	Connection
208-240V	208	3	50/60	1/0	137.6	150	49.6	L1, L2, L3, G
	240	3	50/60	1/0	158.8	175	66.0	L1, L2, L3, G
380-415V	380	3	50/60	1	84.2	100	56.4	L1, L2, L3, N, G
	415	3	50/60	1/0	91.7	100	66.0	L1, L2, L3, N, G
440-480V	440	3*	50/60	2	72.7	80	56.5	L1, L2, L3, G
	480	3*	50/60	1	79.4	80	66.0	L1, L2, L3, G

Electrical connections must meet all applicable federal, state, and local codes. No cord, no plug, dedicated circuit required.

\*Electrical service charge applies.



## Water requirements (per oven)

- Two cold water inlets - drinking quality
- One treated water inlet: 3/4" NPT connection. Line pressure 30 psi minimum dynamic and 90 psi maximum static [200-600 kPa] at a minimum flow rate of 0.26 gpm [1 L/min].
- One untreated water inlet: 3/4" NPT connection. Line pressure 30 psi minimum dynamic and 90 psi maximum static [200-600 kPa] at a minimum flow rate of 2.64 gpm [10 L/min]. Water drain: 1-1/2" [40mm] connection with a vertical vent to extend above the exhaust vent. Materials must withstand temperatures up to 200°F [93°C].

## Water Quality Standards

It is the sole responsibility of the owner/operator/purchaser of this equipment to verify that the incoming water supply is comprehensively tested and, if required, a means of "water treatment" provided that would meet compliance requirements with the published water quality standards shown below. Non-compliance with these minimum standards will potentially damage this equipment and/or components and void the original equipment manufacturer's warranty. Alto-Shaam recommends using the Alto-Shaam Reverse Osmosis System to properly treat your water.

Inlet Water Requirements		
Contaminant	Treated Water	Untreated Water
Free Chlorine	Less than 0.1 ppm (mg/L)	Less than 0.1 ppm (mg/L)
Hardness	30-70 ppm	30-70 ppm
Chloride	Less than 30 ppm (mg/L)	Less than 30 ppm (mg/L)
pH	7.0 to 8.5	7.0 to 8.5
Silica	Less than 12 ppm (mg/L)	Less than 12 ppm (mg/L)
Total Dissolved Solids (tds)	50-125 ppm	50-360 ppm



## Clearance requirements for water filtration system

Do not install a water filtration system behind unit.

Архангельск (8182)63-90-72  
Астана (7172)727-132  
Астрахань (8512)99-46-04  
Барнаул (3852)73-04-60  
Белгород (4722)40-23-64  
Брянск (4832)59-03-52  
Владивосток (423)249-28-31  
Волгоград (844)278-03-48  
Вологда (8172)26-41-59  
Воронеж (473)204-51-73  
Екатеринбург (343)384-55-89  
Иваново (4932)77-34-06

Ижевск (3412)26-03-58  
Иркутск (395)279-98-46  
Казань (843)206-01-48  
Калининград (4012)72-03-81  
Калуга (4842)92-23-67  
Кемерово (3842)65-04-62  
Киров (8332)68-02-04  
Краснодар (861)203-40-90  
Красноярск (391)204-63-61  
Курск (4712)77-13-04  
Липецк (4742)52-20-81  
Киргизия (996)312-96-26-47

Магнитогорск (3519)55-03-13  
Москва (495)268-04-70  
Мурманск (8152)59-64-93  
Набережные Челны (8552)20-53-41  
Нижний Новгород (831)429-08-12  
Новокузнецк (3843)20-46-81  
Новосибирск (383)227-86-73  
Омск (3812)21-46-40  
Орел (4862)44-53-42  
Оренбург (3532)37-68-04  
Пенза (8412)22-31-16  
Казахстан (772)734-952-31

Пермь (342)205-81-47  
Ростов-на-Дону (863)308-18-15  
Рязань (4912)46-61-64  
Самара (846)206-03-16  
Санкт-Петербург (812)309-46-40  
Саратов (845)249-38-78  
Севастополь (8692)22-31-93  
Симферополь (3652)67-13-56  
Смоленск (4812)29-41-54  
Сочи (862)225-72-31  
Ставрополь (8652)20-65-13  
Таджикистан (992)427-82-92-69

Сургут (3462)77-98-35  
Тверь (4822)63-31-35  
Томск (3822)98-41-53  
Тула (4872)74-02-29  
Тюмень (3452)66-21-18  
Ульяновск (8422)24-23-59  
Уфа (347)229-48-12  
Хабаровск (4212)92-98-04  
Челябинск (351)202-03-61  
Череповец (8202)49-02-64  
Ярославль (4852)69-52-93