

# Vector® H Series Multi-Cook Oven

## UL-Listed

Providing an unmatched volume and variety of food, Vector H Series countertop models are specifically designed for foodservice operations where space is at a premium but food demand is high.

Featuring up to four independent oven chambers, operators can control the temperature, fan speed and cook time in each individual chamber for maximum flexibility – simultaneously cooking a variety of menu items with no flavor transfer.

Exclusive Structured Air Technology® delivers focused heat for faster, more even cooking and consistent, high-quality results.

Reduce labor by eliminating extra steps in food production and the need to watch and rotate pans.

Place anywhere with a small, 21" (533mm) footprint and ventless, waterless operation.

Custom colors available for enhanced branding and a front-of-house experience for customers.

An advanced control – designed intentionally simple – features an intuitive, user-friendly interface and programmable recipes to ensure consistency with each cook.

ChefLinc™, cloud-based remote oven management software, streamlines processes and maximizes profits with data-driven insights (deluxe control only).

ISO 9001:2015-certified



VMC-H4

VMC-H3

VMC-H2

### Standard Features

- Programmable, touchscreen control
- Easy recipe upload/download via USB port
- UL-listed ventless catalytic converter
- Double-pane glass door
- One (1) wire stainless steel rack and two (2) jet plates per cooking chamber
- 4" (102mm) adjustable legs
- Cord and plug on 208-240V models (except Canada)



CAPACITY

- VMC-H2: 2 shelf, 2 half-size sheet pans—18" x 13" x 1" [2 GN 2/3 pans—354mm x 325mm x 25mm]
- VMC-H3: 3 shelf, 3 half-size sheet pans—18" x 13" x 1" [3 GN 2/3 pans—354mm x 325mm x 25mm]
- VMC-H4: 4 shelf, 4 half-size sheet pans—18" x 13" x 1" [4 GN 2/3 pans—354mm x 325mm x 25mm]
- VMC-H2H: 2 shelf, 2 full-size hotel pans—20-3/4" x 12-3/4" x 4" [2 GN 1/1 pans—530mm x 325mm x 65mm] or 2 half-size sheet pans—18" x 13" x 1" [2 GN 2/3 pans—354mm x 325mm x 25mm]
- VMC-H3H: 3 shelf, 3 full-size hotel pans—20-3/4" x 12-3/4" x 4" [3 GN 1/1 pans—530mm x 325mm x 65mm] or 3 half-size sheet pans—18" x 13" x 1" [3 GN 2/3 pans—354mm x 325mm x 25mm]
- VMC-H4H: 4 shelf, 4 full-size hotel pans—20-3/4" x 12-3/4" x 4" [4 GN 1/1 pans—530mm x 325mm x 65mm] or 4 half-size sheet pans—18" x 13" x 1" [4 GN 2/3 pans—354mm x 325mm x 25mm]

Архангельск (8182)63-90-72  
Астана (7172)727-132  
Астрахань (8512)99-46-04  
Барнаул (3852)73-04-60  
Белгород (4722)40-23-64  
Брянск (4832)59-03-52  
Владивосток (423)249-28-31  
Волгоград (844)278-03-48  
Вологда (8172)26-41-59  
Воронеж (473)204-51-73  
Екатеринбург (343)384-55-89  
Иваново (4932)77-34-06

Ижевск (3412)26-03-58  
Иркутск (395)279-98-46  
Казань (843)206-01-48  
Калининград (4012)72-03-81  
Калуга (4842)92-23-67  
Кемерово (3842)65-04-62  
Киров (8332)68-02-04  
Краснодар (861)203-40-90  
Красноярск (391)204-63-61  
Курск (4712)77-13-04  
Липецк (4742)52-20-81  
Киргизия (996)312-96-26-47

Магнитогорск (3519)55-03-13  
Москва (495)268-04-70  
Мурманск (8152)59-64-93  
Набережные Челны (8552)20-53-41  
Нижний Новгород (831)429-08-12  
Новокузнецк (3843)20-46-81  
Новосибирск (383)227-86-73  
Омск (3812)21-46-40  
Орел (4862)44-53-42  
Оренбург (3532)37-68-04  
Пenza (8412)22-31-16  
Киргизия (772)734-952-31

Пермь (342)205-81-47  
Ростов-на-Дону (863)308-18-15  
Рязань (4912)46-61-64  
Самара (846)206-03-16  
Санкт-Петербург (812)309-46-40  
Саратов (845)249-38-78  
Севастополь (8692)22-31-93  
Симферополь (3652)67-13-56  
Смоленск (4812)29-41-54  
Сочи (862)225-72-31  
Ставрополь (8652)20-65-13  
Таджикистан (992)427-82-92-69

Сургут (3462)77-98-35  
Тверь (4822)63-31-35  
Томск (3822)98-41-53  
Тула (4872)74-02-29  
Тюмень (3452)66-21-18  
Ульяновск (8422)24-23-59  
Уфа (347)229-48-12  
Хабаровск (4212)92-98-04  
Челябинск (351)202-03-61  
Череповец (8202)49-02-64  
Ярославль (4852)69-52-93

### Configurations (select one)

#### Models

These models accommodate a half-size sheet pan

- VMC-H2  VMC-H3  
 VMC-H4

These models accommodate a full-size hotel pan

- VMC-H2H  VMC-H3H  
 VMC-H4H

#### Control

- Deluxe  Simple

#### Kit

- Ethernet Cable [5030518] for Deluxe only

#### Door swing

- Right hinged  Left hinged

#### Electrical

##### VMC-H2/H2H

- 208-240V, 1PH, with cord and plug  
 208-240V, 1PH, no cord, no plug [Canada]  
 220-240V, 1PH, no cord, no plug  
 380-415V, 3PH, no cord, no plug

##### VMC-H3/H3H

- 208-240V, 1PH, with cord and plug  
 208-240V, 1PH, no cord, no plug [Canada]  
 208-240V, 3PH, with cord and plug  
 208-240V, 3PH, no cord, no plug [Canada]  
 220-240V, 1PH, no cord, no plug  
 380-415V, 3PH, no cord, no plug

##### VMC-H4/H4H

- 208-240V, 3PH, with cord and plug  
 208-240V, 3PH, no cord, no plug [Canada]  
 380-415V, 3PH, no cord, no plug

### Accessories (select all that apply)

- See accessories brochure for all available accessories

#### Casters and legs

- 3" (76mm) casters, set of four [4] [5027946]

#### Cookware

- Jet plate assembly, half-size sheet pan [5025235]  
 Jet plate assembly, hotel pan [5025236]  
 Wire shelf, half-size sheet pan [SH-37662]  
 Wire shelf, hotel pan [SH-39077]

# Vector® H Series Multi-Cook Oven

## Specification

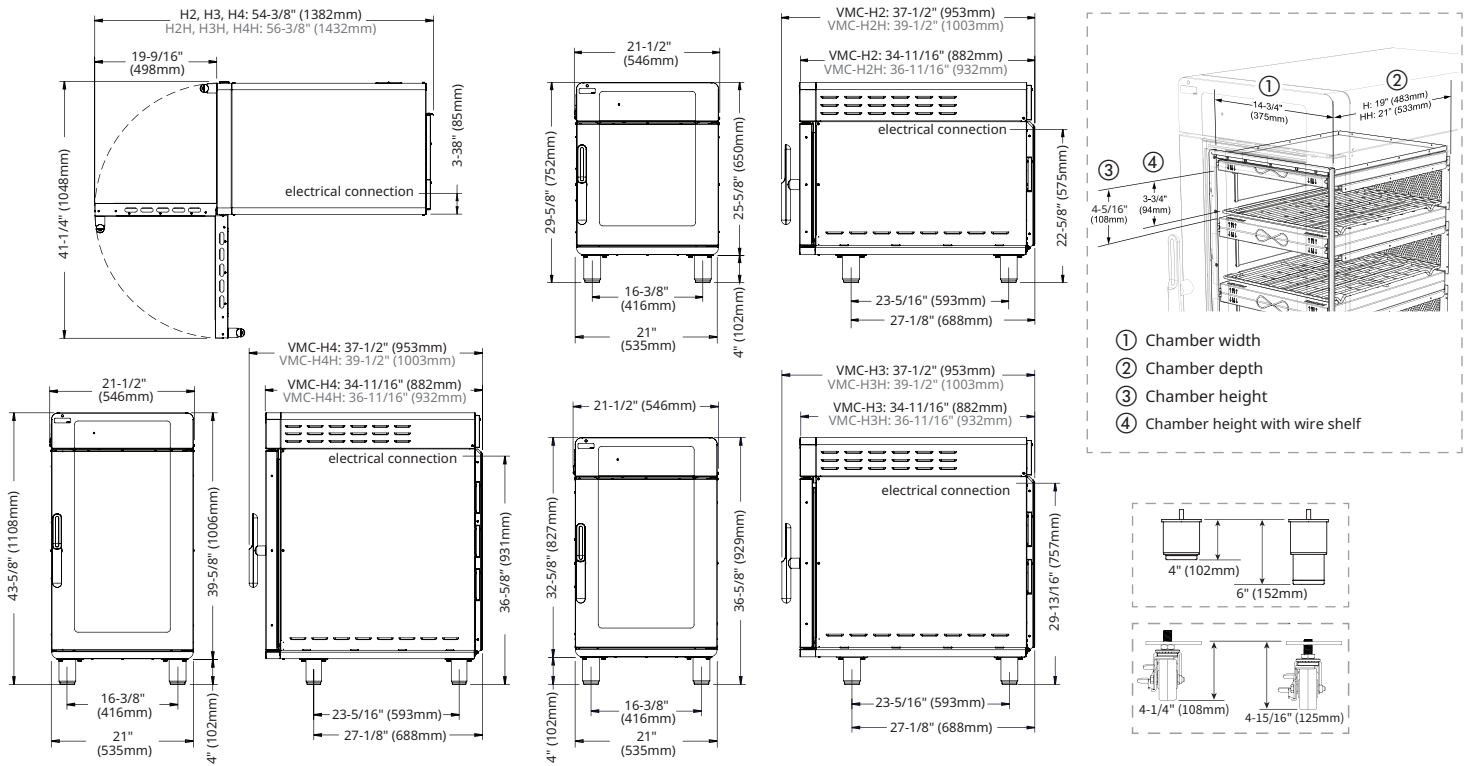

DIMENSIONS

Model	Exterior (H x W x D)	Interior (H x W x D)	Net Weight
VMC-H2	29-5/8" x 21-1/2" x 37-1/2" [752mm x 546mm x 953mm]	14-3/8" x 14-11/16" x 19" [366mm x 373mm x 483mm]	209 lb [95 kg]
VMC-H2H	29-5/8" x 21-1/2" x 39-1/2" [752mm x 546mm x 1003mm]	14-3/8" x 14-11/16" x 21-1/2" [366mm x 373mm x 546mm]	213 lb [97 kg]
VMC-H3	36-5/8" x 21-1/2" x 37-1/2" [929mm x 546mm x 953mm]	21-3/8" x 14-11/16" x 19" [544mm x 373mm x 483mm]	272 lb [123 kg]
VMC-H3H	36-5/8" x 21-1/2" x 39-1/2" [929mm x 546mm x 1003mm]	21-3/8" x 14-11/16" x 21-1/2" [544mm x 373mm x 546mm]	278 lb [126 kg]
VMC-H4	43-5/8" x 21-1/2" x 37-1/2" [1108mm x 546mm x 953mm]	28-3/8" x 14-11/16" x 19" [721mm x 373mm x 483mm]	341 lb [155 kg]
VMC-H4H	43-5/8" x 21-1/2" x 39-1/2" [1108mm x 546mm x 1003mm]	28-3/8" x 14-11/16" x 21-1/2" [721mm x 373mm x 546mm]	348 lb [158 kg]

Model	Ship Dimensions (L x W x H)*	Ship Weight*
VMC-H2/H	48" x 29" x 56" [1219mm x 737mm x 1422mm]	291 lb [132 kg]
VMC-H3/H	48" x 29" x 56" [1219mm x 737mm x 1422mm]	375 lb [170 kg]
VMC-H4/H	48" x 29" x 56" [1219mm x 737mm x 1422mm]	425 lb [193 kg]

\*Domestic ground shipping information. Contact factory for export weight and dimensions.

# Vector® H Series Multi-Cook Oven



Top: 2" [51mm]\*  
 Left: 2" [51mm]  
 Right: 2" [51mm]  
 Front: 20" [508mm]  
 Back: 2" [51mm]

\* 18" [457mm] recommended for service access



**CHECK FIRST**

- The oven must be installed level.
- The oven must not be installed in any area where it may be affected by steam, grease, dripping water, high temperatures, or any other severely adverse conditions.
- Oven not intended for built-in installation.



**HEAT**

## Heat of rejection

VMC-H	Heat Gain qs, BTU/hr	Heat Gain qs, kW
	1,898	0.56



**TEMPERATURE**

Maximum temperature: 525°F [274°C]



**ELECTRIC**

VMC-H2/VMC-H2H	V	Ph	Hz	Awg	IEC	A	Breaker [A]	kW	Plug Configuration**
208–240V	208	1	60	8	—	25	30*	5.2	NEMA 6-30
	240	1	60	8	—	28	30*	6.7	NEMA 6-30
220–240V	220	1	50/60	—	4	25	32*	5.4	No cord, no plug
	240	1	50/60	—	4	28	32*	6.4	No cord, no plug
380–415V	380	3	50/60	—	1.5	8	16	5.4	No cord, no plug
	415	3	50/60	—	1.5	9	16	6.4	No cord, no plug
<b>VMC-H3/VMC-H3H</b>									
208–240V	208	1	60	6	—	38	50*	7.9	NEMA 6-50
	240	1	60	6	—	43	50*	10.3	NEMA 6-50
208–240V	208	3	60	10	—	22	30	7.9	NEMA 15-30P
	240	3	60	10	—	25	30	10.3	NEMA 15-30P
220–240V	220	1	50/60	6	10	37	63	8.1	No cord, no plug
	240	1	50/60	6	10	41	63	9.6	No cord, no plug
380–415V	380	3	50/60	—	1.5	13	16	8.1	No cord, no plug
	415	3	50/60	—	1.5	14	16	9.6	No cord, no plug
<b>VMC-H4/VMC-H4H</b>									
208–240V	208	3	60	6	—	32	40	10.6	NEMA 15-50P
	240	3	60	6	—	36	40	13.9	NEMA 15-50P
380–415V	380	3	50/60	—	4	17	32	10.8	No cord, no plug
	415	3	50/60	—	4	18	32	12.7	No cord, no plug

Electrical connections must meet all applicable federal, state, and local codes.

\* For use on individual branch circuit only.

\*\* No cord, no plug, in Canada.

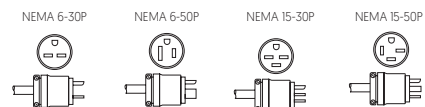

# Vector® H Series Multi-Cook Oven

## Stacked Configurations and Stands

### VMC-H on stand 5028223

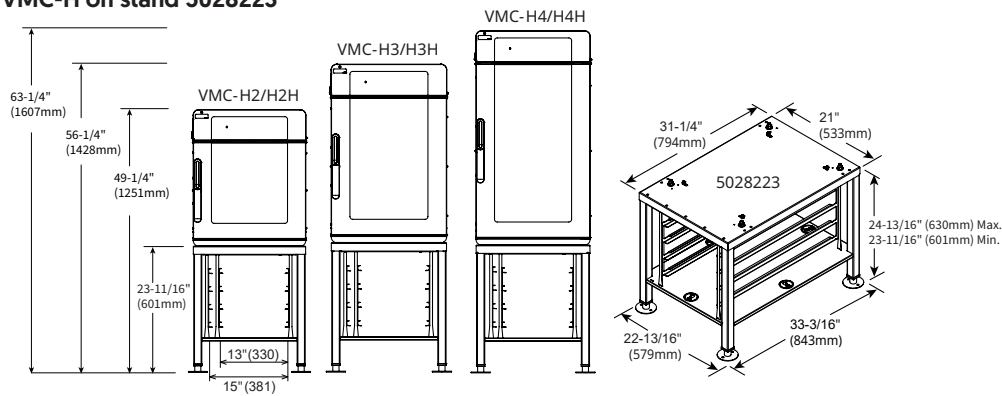

Dimensions shown are with adjustable feet at minimum height.

### VMC-H on stand 5028173

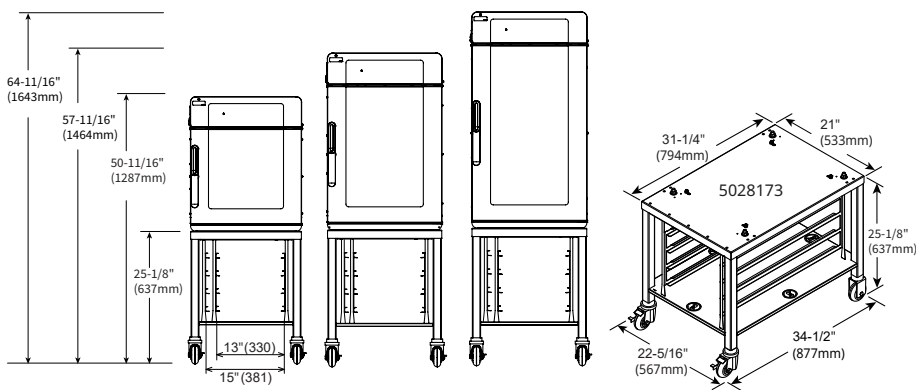

### VMC-H on stand 5027644

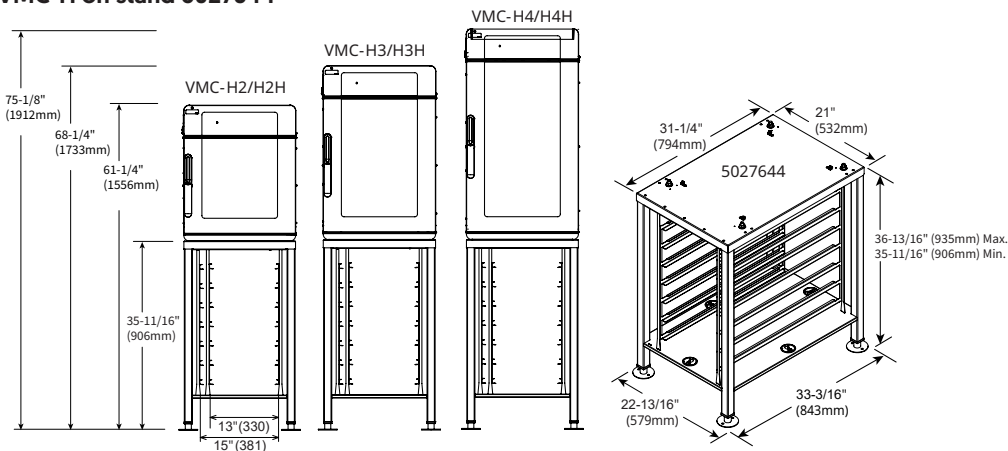

Dimensions shown are with adjustable feet at minimum height.

# Vector® H Series Multi-Cook Oven

## Stacked Configurations and Stands

**VMC-H2 on stand 5027834 over VMC-H2 or VMC-H2H on stand 5030180 with casters**

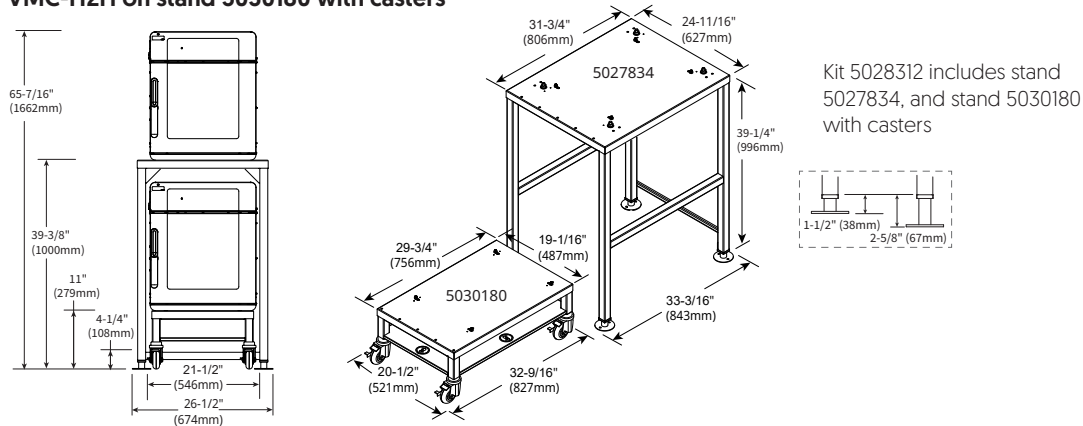

Dimensions shown are with adjustable feet at minimum height.

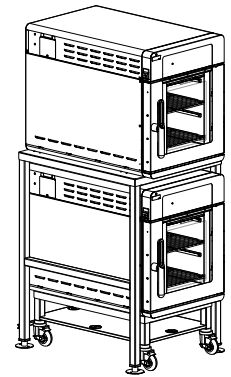

**VMC-H on stand 5027834 over VMC-H3 or VMC-H3H with casters**

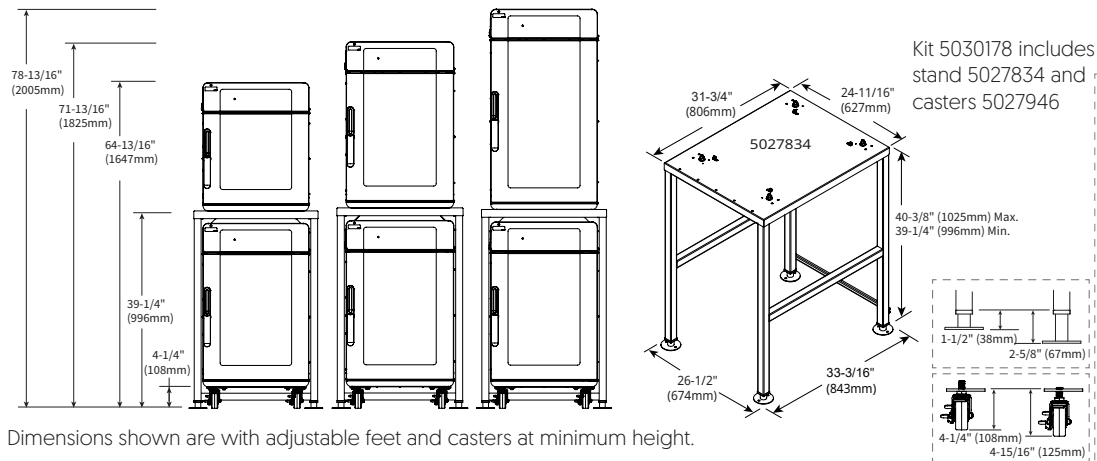

Dimensions shown are with adjustable feet and casters at minimum height.

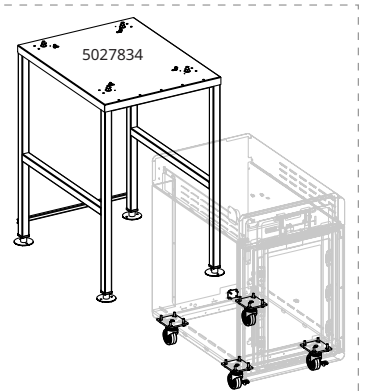

**VMC-H2, VMC-H2H, VMC-H3, or VMC-H3H on stand 5027835 over VMC-H4 or VMC-H4H (a VMC-H4 or VMC-H4H cannot be stacked on top of this stand)**

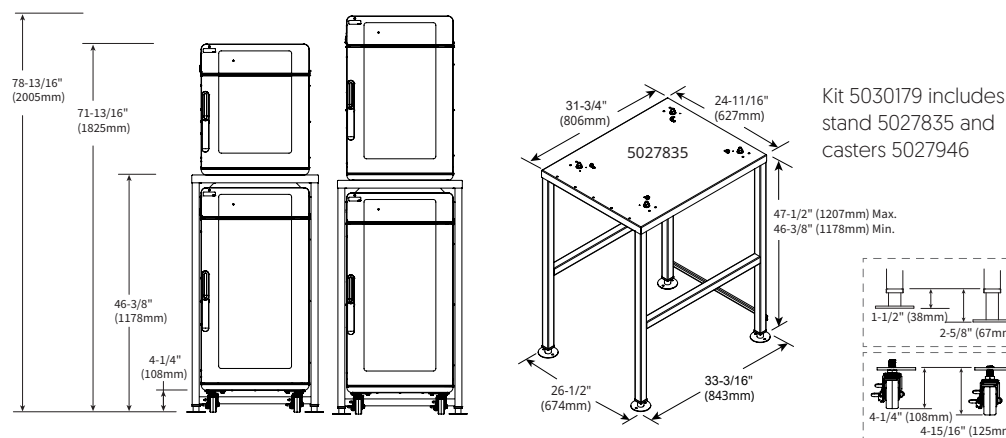

Dimensions shown are with adjustable feet and casters at minimum height.

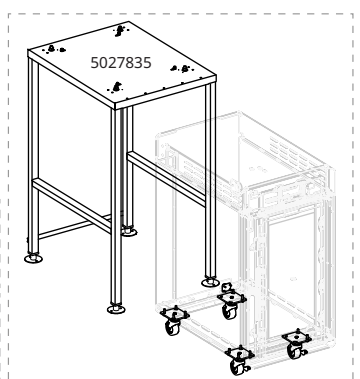

# Vector® H Series Multi-Cook Oven

## Alternative Stacked Configurations and Stands

### VMC-H on stand 5027762 over 750-S, 750-TH/II, 750-TH/III, or 767-SK/III\*

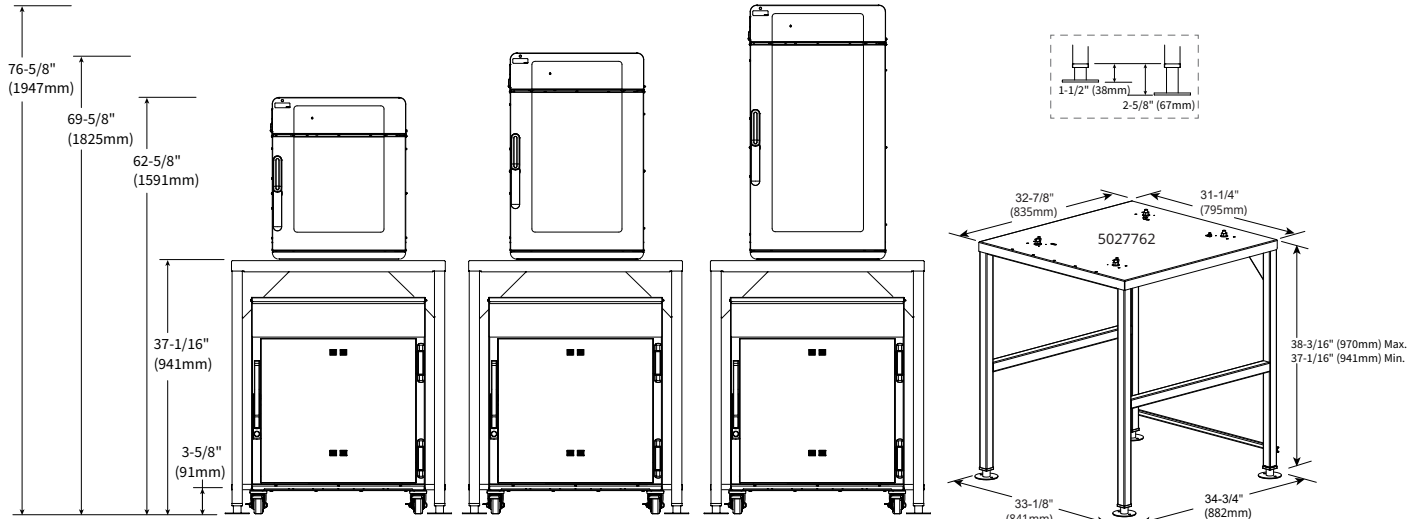

Dimensions shown are with adjustable feet at minimum height.  
\*Smoker models must be under a hood.

### VMC-H on stand 5030611 over 750-S, 750-TH/II, 750-TH/III, or 767-SK/III\*

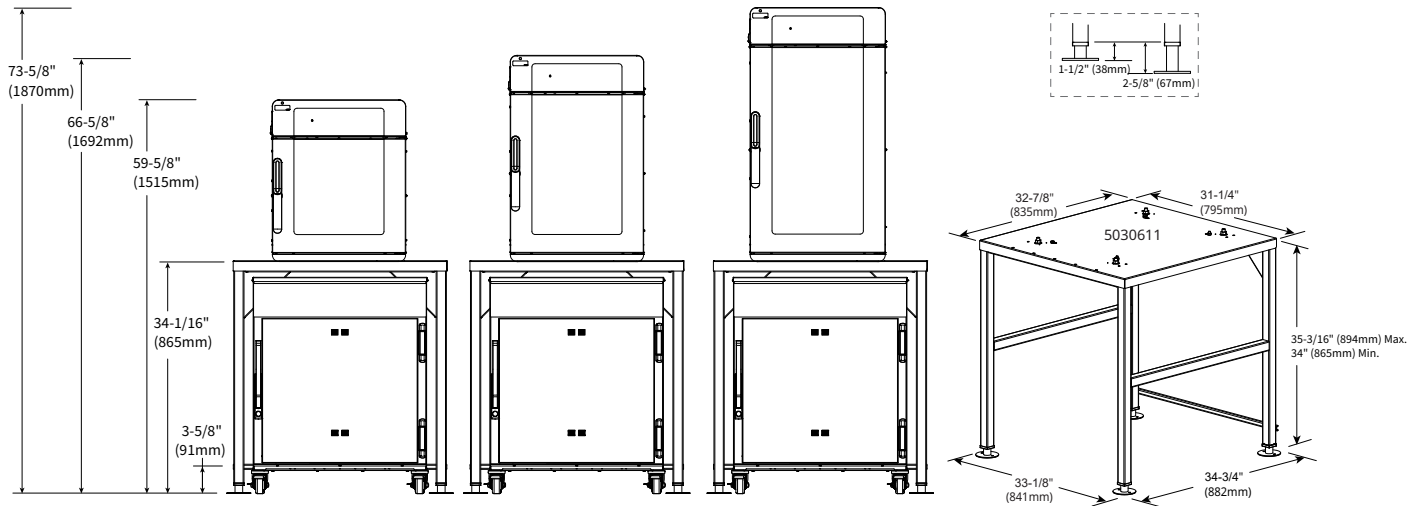

Dimensions shown are with adjustable feet at minimum height.  
\*Smoker models must be under a hood.

# Vector® H Series Multi-Cook Oven

## Alternative Stacked Configurations and Stands

### VMC-H on stand 5027834 over 500-S, 500-TH/II, or 500-TH/III

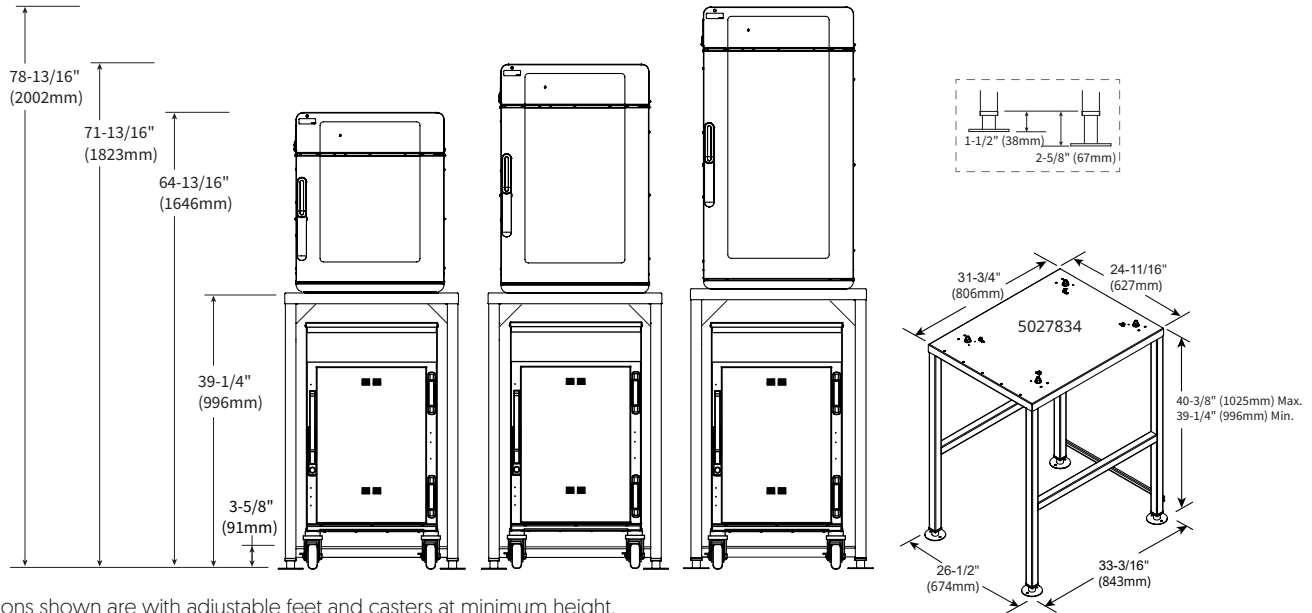

Dimensions shown are with adjustable feet and casters at minimum height.

### CTX4-10 on stand 5028514 over VMC-H3 or VMC-H3H

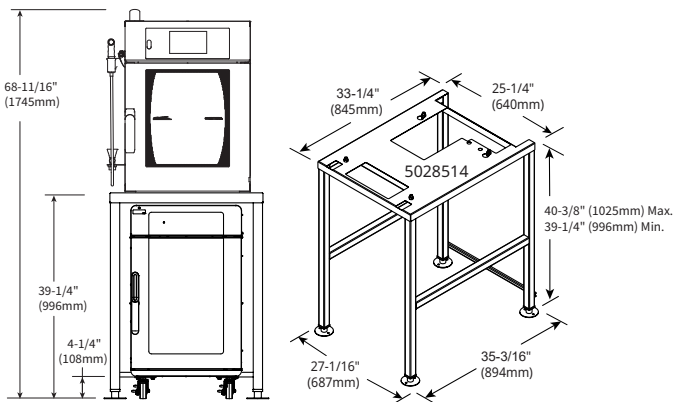

### CTX4-10 on stand 5028516 over VMC-H4 or VMC-H4H

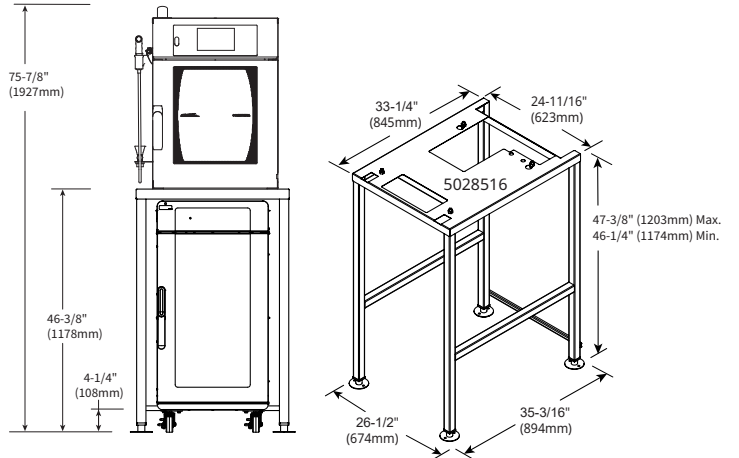

Dimensions shown are with adjustable feet and casters at minimum height.

**Архангельск** (8182)63-90-72  
**Астана** (7172)727-132  
**Астрахань** (8512)99-46-04  
**Барнаул** (3852)73-04-60  
**Белгород** (4722)40-23-64  
**Брянск** (4832)59-03-52  
**Владивосток** (423)249-28-31  
**Волгоград** (844)278-03-48  
**Вологда** (8172)26-41-59  
**Воронеж** (473)204-51-73  
**Екатеринбург** (343)384-55-89  
**Иваново** (4932)77-34-06

**Ижевск** (3412)26-03-58  
**Иркутск** (395)279-98-46  
**Казань** (843)206-01-48  
**Калининград** (4012)72-03-81  
**Калуга** (4842)92-23-67  
**Кемерово** (3842)65-04-62  
**Киров** (8332)68-02-04  
**Краснодар** (861)203-40-90  
**Красноярск** (391)204-63-61  
**Курск** (4712)77-13-04  
**Липецк** (4742)52-20-81  
**Киргизия** (996)312-96-26-47

**Магнитогорск** (3519)55-03-13  
**Москва** (495)268-04-70  
**Мурманск** (8152)59-64-93  
**Набережные Челны** (8552)20-53-41  
**Нижний Новгород** (831)429-08-12  
**Новокузнецк** (3843)20-46-81  
**Новосибирск** (383)227-86-73  
**Омск** (3812)21-46-40  
**Орел** (4862)44-53-42  
**Оренбург** (3532)37-68-04  
**Пенза** (8412)22-31-16  
**Казахстан** (772)734-952-31

**Пермь** (342)205-81-47  
**Ростов-на-Дону** (863)308-18-15  
**Рязань** (4912)46-61-64  
**Самара** (846)206-03-16  
**Санкт-Петербург** (812)309-46-40  
**Саратов** (845)249-38-78  
**Севастополь** (8692)22-31-93  
**Симферополь** (3652)67-13-56  
**Смоленск** (4812)29-41-54  
**Сочи** (862)225-72-31  
**Ставрополь** (8652)20-65-13  
**Таджикистан** (992)427-82-92-69

**Сургут** (3462)77-98-35  
**Тверь** (4822)63-31-35  
**Томск** (3822)98-41-53  
**Тула** (4872)74-02-29  
**Тюмень** (3452)66-21-18  
**Ульяновск** (8422)24-23-59  
**Уфа** (347)229-48-12  
**Хабаровск** (4212)92-98-04  
**Челябинск** (351)202-03-61  
**Череповец** (8202)49-02-64  
**Ярославль** (4852)69-52-93